

Accuride®

Model 123 with European Hinge
Model 1234 without hinge
 Clip-On Hinge
 Flipper Door Slide®
 Up to 30 lb. Capacity

APPLICATIONS: Concealed doors of entertainment centers, wall units, cabinets. Used for horizontal and vertical door applications up to 42" tall.

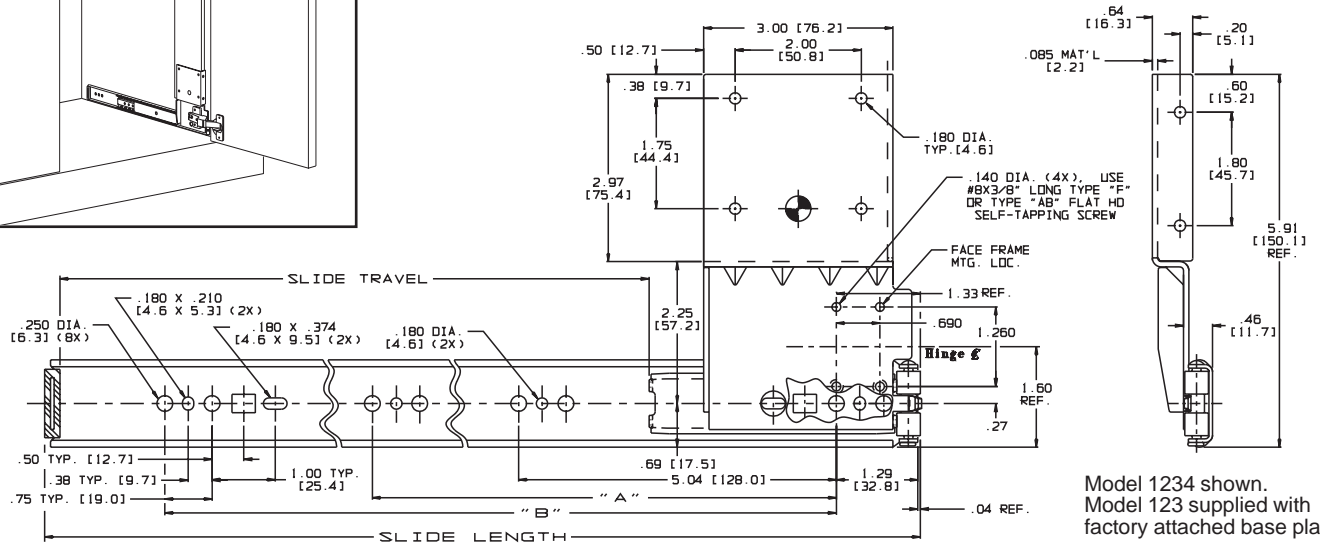
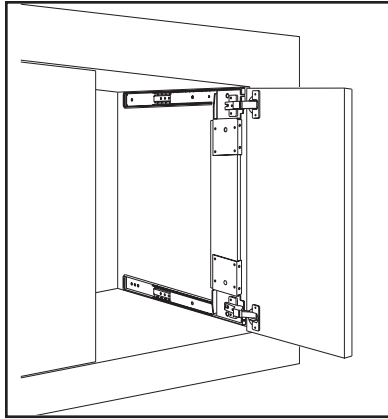

Model 1234 shown.
 Model 123 supplied with factory attached base plate.



- Finish** Black zinc plating
- Door Sizes** 5/8" thick min., 1-1/4" thick max. up to 24" wide. When door thickness exceeds 13/16", or for overlay style doors, a 40mm hinge is required and can be purchased separately.
- Length** 12" to 28"
- Travel** See chart.
- Load Rating** Up to 30 lbs.
- Also** Detent out, door gap can be minimized to zero.

Part Number	Slide Length	Slide Travel	"A"	"B"
12	11.94 [303]	7.40 [188]	-	8.82 [224]
14	13.94 [354]	9.40 [239]	-	8.82 [224]
16	15.94 [405]	11.40 [289]	-	12.60 [320]
18	17.94 [456]	13.40 [340]	-	13.86 [352]
20	19.94 [506]	15.40 [391]	-	16.38 [416]
22	21.94 [557]	17.40 [442]	13.86 [352]	18.90 [480]
24	23.94 [608]	19.40 [493]	13.86 [352]	18.90 [480]
26	25.94 [659]	21.40 [543]	13.86 [352]	21.42 [544]
28	27.94 [710]	23.40 [594]	13.86 [352]	23.94 [608]

Step 1

Model 1234 Before installing slide, attach base plate to holes on inner member plate using the provided #8 x 3/8" self tapping screws (See front page for exact hole location). The screws provided are for use with hinges which utilize a 0mm base spacer. Using a thicker spacer will require more room and may not allow the screw to properly engage the inner member plate. A longer screw thread may be required. Contact the hinge manufacturer for further information.

Model 123 & 1234 Position slides against the ceiling and floor of the cabinet and inset from the front 1/8" plus the door thickness. A shim block of the correct measurement can be used to locate the slide front exactly as shown in Figure 1.

Install screws in front and rear slots.

Step 2

Cut follower strip 6" shorter than door height. Maximum thickness for follower strip is 3/4". Position follower strip under mounting plate against the front angle and pull slides forward as shown in Figure 2. This will align both slides parallel. Hold in place and install screws.

Step 3

Model 1234 Use the table on the back page to determine tab and gap dimensions for hinge of choice. Bore cup holes 1-1/2" from door top and bottom. Install door and adjust as required.

Model 123 Bore 35mm clip-on hinge cup holes 1-1/2"* from the door top and bottom (1/4" tab) as shown in Figure 3. Install door and adjust as required.

* This presumes a top and bottom gap of 1/8" with the door 1/4" shorter than the cabinet opening.

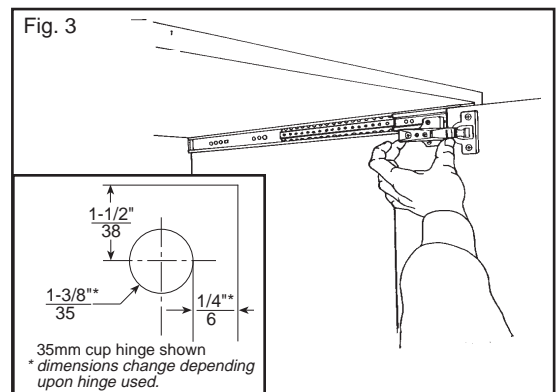
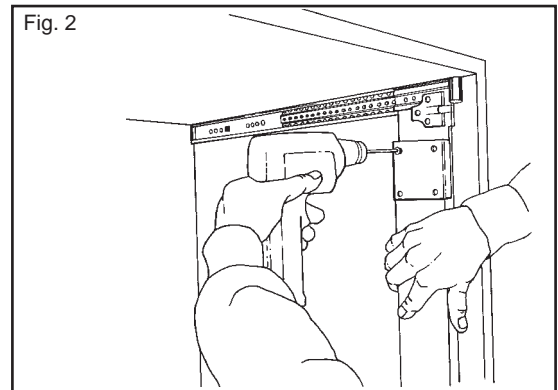
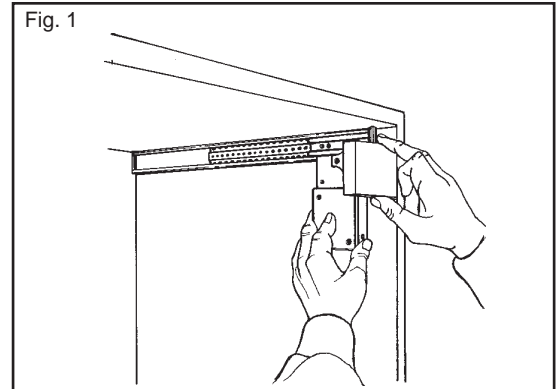

Placement of pivot block

Two pivot blocks are included in the supplied hardware kit. The purpose of the pivot blocks is to prevent premature rotation of the cabinet door, which can result in scarring of the front face of the door. Refer to Figure 4 for location of block at top and bottom of case. Use two blocks per door. Block should just touch the back side of the door in both the open and closed positions. The deck of the pivot block is a built-in gauge for 3/4" thick doors. For partition placement, see dimension "A" on next page for operating envelope information.

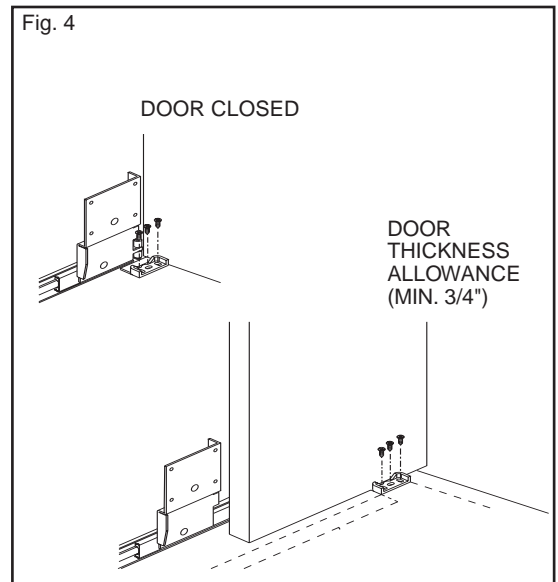

Refer to the illustrations below and the chart on page 4 to determine hinge placement for the various applications shown.

Inset Application

Inset Application for door thicknesses 3/4" - 1-1/4".

35mm hinge and base is supplied by Accuride, for doors up to 13/16" thick (Model 123 only). For doors exceeding 13/16", use the optional 40mm hinge kit specified below.

Refer to the chart on the following page for tab and door thickness information.

The hinge base attached to the slide can be used with any Mepla hinge specified on the following page. When using a Mepla 40mm hinge, spacers are required for doors over 1" thick.

Optional 40mm Hinge Kit
Accuride P/N 4180-0313-XE

Open Position

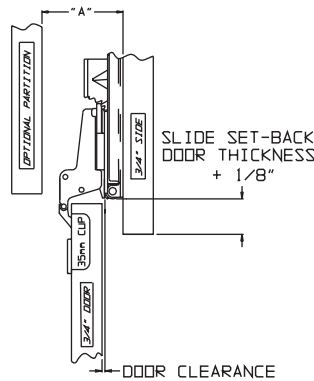

Closed Position

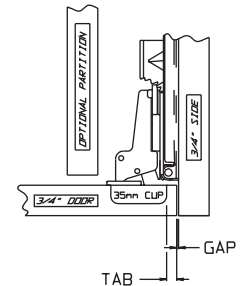

"A" = 2" 35mm Mepla, 35mm Blum, or 35mm Grass
2-1/2" 40mm Salice or 40mm Mepla

Overlay Application

Maximum Door Thickness up to 15/16" depending upon hinge used. Requires a 40mm cup hinge.

Refer to the chart on the following page for tab, door thickness and overlay information.

If an overlay installation is desired, please specify the optional hinge kit listed below.

Optional 40mm Hinge Kit
Accuride Part Number 4180-0314-XE

Open Position

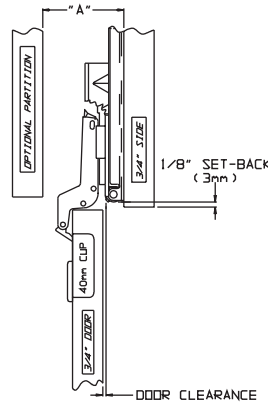

Closed Position

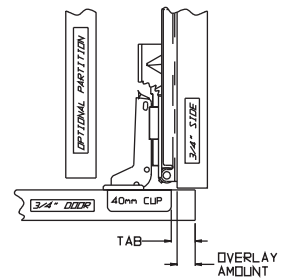

"A" = 2" Salice
2-1/4" Mepla

Face Frame Overlay Application

Maximum door thickness up to 13/16" depending upon hinge used.

All specifications for this installation are the same as the above overlay installation, with the following exceptions:

The hinge base plate must be moved forward to the two front face frame holes as indicated in the right hand drawing. Maximum face frame dimension is 1-1/8".

Use 35mm hinge and base as supplied by Accuride.

Open Position

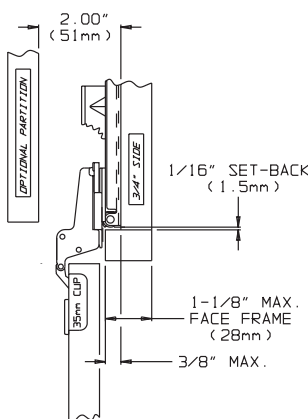

Closed Position

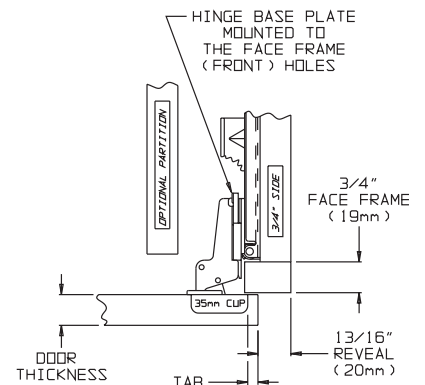

Clip-On Hinge Options/Ordering Instructions

Application	Hinge Cup	Mfg P/N	Door Thickness		Max. Tab		Min. Gap		Door Clearance					
			mm	inches	mm	inches	mm	inches	mm	inches				
Inset	35mm	Mepla (Supplied) DS05-253S/08	19	3/4	6	1/4	0.7	1/32	2	5/64				
			20.6	13/16					0.4	1/64				
			20.6	3/4					5.5	7/32				
		Blum 71M9650 0mm Base 175H9100	20.6	13/16	8	5/16	2.2	3/32	3.9	5/32				
			22.2	7/8					2.3	3/32				
			23.8	15/16					0.7	1/32				
			19	3/4					4	11/64				
		Grass 1806VZ 3.5mm base GHRZ3.5/5.2/37 3mm spacer req'd. for all doors	20.6	13/16	5	3/16	0.9	1/32	2.4	3/32				
			22.2	7/8					0.8	1/32				
			19	3/4					5.5	7/32				
Inset for thick doors	40mm	Mepla DS25-253S/08 * Spacers req'd for doors 1" thick & over. DS7250 ES 37/00	19	3/4	6	1/4	0.7	1/32	5.5	7/32				
			20.6	13/16					3.9	5/32				
			22.2	7/8					2.3	3/32				
			23.8	15/16					0.7	1/32				
			25.4	1					2.1	5/64				
			27	1-1/16 *					0.5	1/64				
	40mm	Salice CFA7P99 0mm base BAR3E09	28.6	1-1/8 *	9	3/8	1.7	1/16	1.9	5/64				
			30.2	1-3/16 *					0.3	1/64				
			19	3/4					14	9/16	0.7	1/32	13	1/2
			20.6	13/16									11.4	7/16
			22.2	7/8									9.8	3/8
			23.8	15/16									8.2	5/16
	25.4	1	6.6	1/4										
	27	1-1/16	5	3/16										
	40mm	Salice CFA7G99 0mm Base BAR3E09	28.6	1-1/8	11	7/16	5	3/16	3.4	1/8				
			30.2	1-3/16					0.2	1/16				
			31.8	1-1/4					0.2	0				
			19	3/4					15	19/32	11.3	7/16	2	5/64
20.6			13/16	0.4									1/64	
19			3/4	11									7/16	5
20.6	13/16	3.9	5/32											
22.2	7/8	2.3	3/32											
23.8	15/16	0.7	1/32											
Overlay Amount														
Overlay	40mm	Salice CFA7G99 0mm Base BAR3E09	19		3/4	15	19/32	11.3	7/16	2	5/64			
			20.6	13/16	0.4					1/64				
			19	3/4	11					7/16	5	3/16	5.5	7/32
		20.6	13/16	3.9		5/32								
		22.2	7/8	2.3		3/32								
		Mepla DS 25-253 S/08	23.8	15/16	11	7/16	5	3/16	0.7	1/32				

Slide Ordering Procedure

Complete your slide order for Accuride 123/1234 Flipper Door Model by specifying the following:

Total Required Slides 100 Each CB 123 -12 D
 Black Finish _____
 Slide Model _____
 Slide Length _____
 Polybag Packaging - includes hardware kit _____

123 Packaging

Distributor (D) Pack for all lengths are packaged 4 sets/box and include the following parts:

- 1 Pair Slides -with base plate attached.
- 1 Each Hinge Kit P/N 4180-0295-XE includes:
 - 2 Each 35mm Black Clip-On Hinge P/N 2990-8665-NE
 - 4 Each #6 Screw P/N 2400-3167-BE
 - 4 Each M6 x 10mm Euro Screw P/N 2410-3216-CE
 - 2 Each Pivot Block P/N 2336-2839-YE
 - 22 Each #8 Screw P/N 2410-3218-BE

1234 Packaging

Distributor (D) Pack for all lengths are packaged 4 sets/box and include the following parts:

- 1 Pair Slides -no base plate attached
- 1 Each Pivot Block Kit P/N 4180-0315-XE includes:
 - 2 Each Pivot Block P/N 2336-2839-YE
 - 22 Each #8 Screw P/N 2410-3218-BE
 - 4 Each #8 Self-tapping Screw P/N 2410-3229-BE

Optional Hardware Kits - Ordered Separately

40mm Salice Clip-On Hinge Kit

For Overlay Installation

Part Number 4180-0314-XE

- 2 Each Hinge P/N 2990-8667-NE
- 2 Each Base Plate P/N 2990-8660-NE
- 4 Each #6 Screw P/N 2400-3167-CE
- 4 Each #8 Screw P/N 2410-3229-BE

40mm Salice Clip-On Hinge Kit Inset for Thick Doors Application Part Number 4180-0313-XE

- 2 Each Hinge P/N 2990-8666-NE
- 2 Each Base Plate P/N 2990-8660-NE
- 4 Each #6 Screw P/N 2400-3167-CE
- 4 Each #8 Screw P/N 2410-3229-BE

Specifications

Slide members and ball retainers: Cold rolled steel
 Ball bearings: Carburized steel
 Hinge: Nickel plated stamped steel

Specifications, materials, prices and delivery are subject to change without notice.

Accuride

Headquarters and Main Plant

12311 Shoemaker Avenue Santa Fe Springs, CA 90670

Customer Service

TEL (562)903-0200 • FAX (562)903-0208

Manufacturing, Engineering and Sales

United States • Germany • Japan • Mexico

United Kingdom

Copyright © 1997 Accuride International Inc.

Printed In U.S.A 3700-9387-(9386)-9052-MK006-R2-0197